

## POSITIVE REFRIGERATION SYSTEM



### Experimental capabilities

- Identification of components of a positive refrigerating system
- Commissioning and verification of operation
- Study of the basic concept of a refrigeration plant to R134A.
- Study of the thermodynamic cycle on enthalpic diagram.
- Study of the regulation
- The system with industrial rendering
- The kit comes assembled, loaded and functional

## Operating principle

The positive refrigeration kit allows the study of positive refrigerating system. The system includes all the standard components such as compressor, condenser, expansion valve, evaporator, bottles, pressure switches.

The kit is supplied complete, assembled and functional. Students can work on identifying the components, commissioning, adjustment and the verification of operation. They will also be able to recover the fluid and the load (requires the tooling not supplied with the bench).

The kit is intended to be assembled with the cold rooms type CHB100 of DIDATEC brand.

The robust design of this equipment makes it perfectly suited for use in schools.

Its structure in anodized aluminum on wheels gives it great strength as well as great flexibility of integration into your premises.

The manufacturing of this equipment meets European machine directive.

## Illustrations

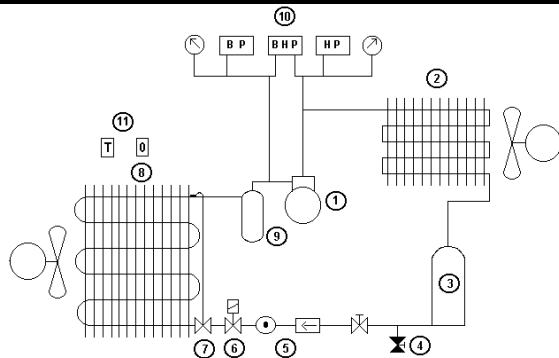

1. A hermetic compressor  
Refrigerant: R134a  
Condensing temperature +40°C  
Evaporation temperature 0°C  
Maximum pressure: 32 bars  
Power: 916W 0°C/32°C  
Equipped with two service valves
2. Air condenser  
forced convection
3. Fluid reservoir  
Steel vertical  
Volume: 1.5L
4. Refrigerant recovery valve
5. Dehydration station  
Solid cartridge dehydrator Ø1/4 "  
Fluid state LED Ø1/4 "
6. An electromagnetic valve  
Normally closed  
Straight passage Ø1/4 "

## Technical specifications

7. Thermostatic expansion valve  
Internal pressure equalization with calibrated orifice (-40°C /+10 °C)
8. Air evaporator  
With forced convection  
Evaporation temperature 0°C  
Power: 665W pour dT=8K
9. A suction line accumulator.  
Steel vertical  
Volume: 1.5L
10. Control and safety system  
High pressure manometer -1 to 30bars  
Low pressure manometer -1 to 10bars  
High pressure switch control  
Low pressure switch control  
HLP combined safety pressure switch  
Safety thermostat

The electrical side of the system includes :

- an electrical cabinet made of steel with a 230VAC plug to connect the accessories.
- the standard safety elements (main switch, emergency stop button, GFCI, connection to earth and white light)
- a circuit breaker for each element
- the relays for the main components of the system (evaporator, electro valve, compressor, condenser, defrost heater)
- lights for each component
- a refrigeration temperature controller with 2 probes to manage all the components (defrost, ventilation...)

## Services required

- Power supply: 230 Vac – 50 Hz –10A
- Power supply Type: 1 phase(s) + Neutral + Earth.
- Dimensions: (LxWxH mm): 800 x 800 x 1700
- weight (Kg): 105

Note : if the equipment installation is operated by our staff, all supplies and exhaust connections required must stand at less than 2m from the machine

## Documentation

- User's manual
- Pedagogical manual
- Technical documentation of the components
- Lab exercises
- Wiring diagram
- Fluidic diagram
- Certificate of conformity CE

## Recommended equipment

- Cold Room

- Ref : CHB 100